

# Chain & Paddle Conveyors

Grain Pump

Commercial Grain Pump

Double Run

Mass-Ter Mover

Mass-Ter Flow

Dual Hopper

Chain Conveyor

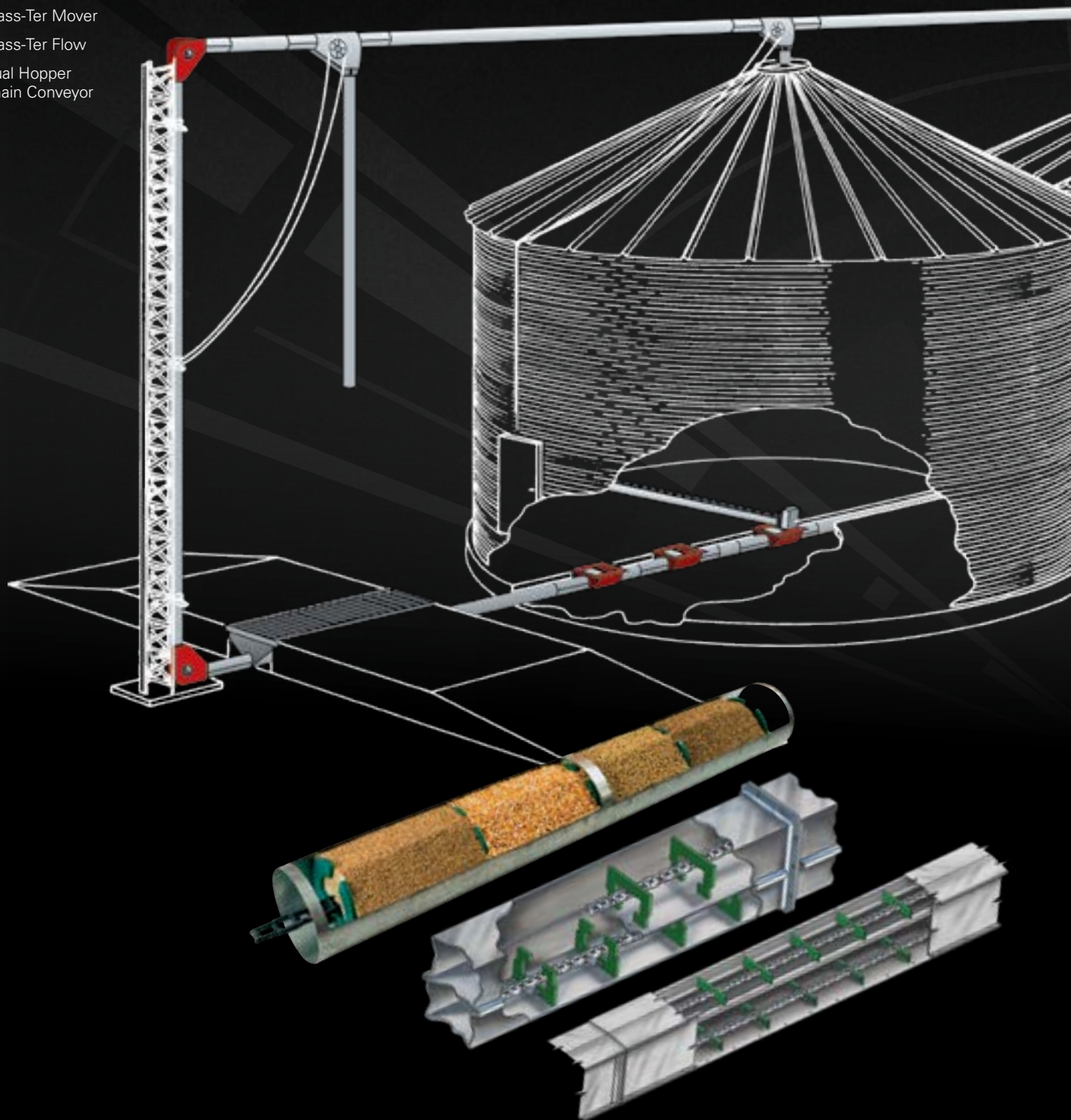



# Quality Equipment on Your Farm

Hutchinson manufactures quality products, including; portable and stationary grain handling equipment, augers, chain & paddle conveyors, belt conveyors, loop systems, bin unloads and custom augers.

# Grain Pump

## Custom Grain Pump™ systems tailored to your storage system.

The innovative Hutchinson Grain Pump™ lets you move grain with gentle efficiency, at high capacities and requires less horsepower than air systems. Hutchinson's en masse (grain-moving-grain) concept causes less damage to grain and needs less maintenance than traditional conveying systems. The secret is Hutchinson's unique Ultra High Molecular Weight (UHMW) paddle, designed to keep your grain flowing gently and evenly from inlet to discharge source. These round plastic paddles are spaced every 10 1/2", taking the place of traditional auger flighting. These paddles are notched to go around corners. Grain Pump™ owners have found a reduction in grain damage when compared to traditional conveying systems.

The closed-loop design offers the versatility to create a complete load-in/load-out system that also provides recirculation capabilities. One or more bins can be unloaded at a time into the loop. Reduced drying costs can be achieved with this innovative system by blending higher moisture and dried grain from one bin to another. Possibilities are nearly unlimited. Install the Grain Pump™ underneath a row of bins (Photo A), in an existing in-line row of bins (Photo B), or in a flat storage structure (Photo C). The loop system may provide future expansion capabilities.

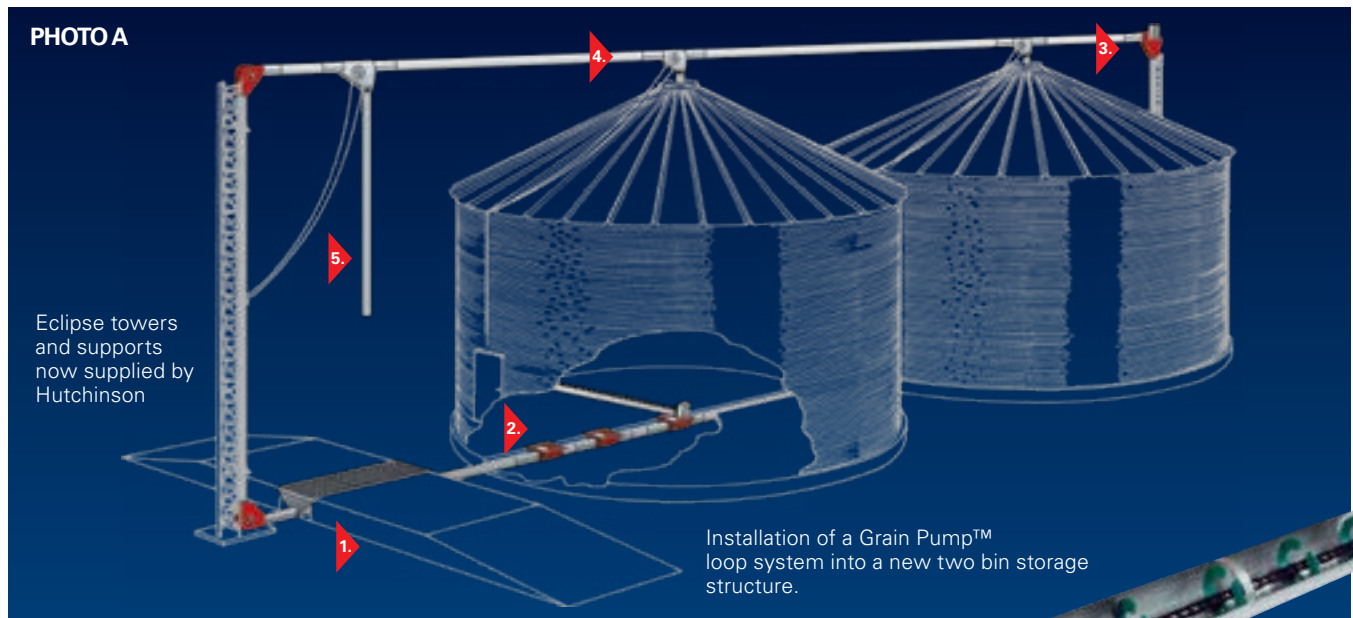

- 1. Drive over Grain Pump pit hopper
- 2. Center and intermediate wells
- 3. Drive corner
- 4. 90° discharge drops with ground control kit
- 5. Complete load out capability
- 6. Patent pending rotary drops with ground control kits

### PHOTO B



### PHOTO C

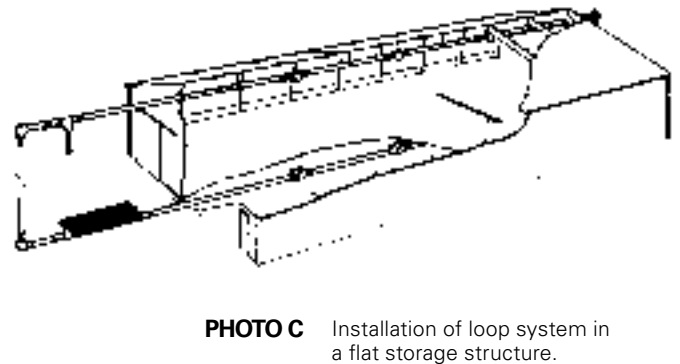

# Grain Pump



Installation of Grain Pump Loop System with a wet bin and dryer application.



Installation of Grain Pump loop system into existing bin structure.

## GRAIN PUMP SPECIFICATIONS

	6" LOOP	8" LOOP	10" LOOP	12" LOOP
DIMENSIONS OF CONVEYING CHAMBER	6" (15.2 cm)	8" (20.3 cm)	10" (25.4 cm)	12" (30.5 cm)
MAXIMUM CAPACITY*	1,500 BPH (41 TPH)	4,000 BPH (108 TPH)	6,000 BPH (162 TPH)	10,000 BPH (270 TPH)
CHAIN TRAVEL	325 FPM (99.1MPM)	325 FPM (99.1 MPM)	325 FPM (99.1 MPM)	400 FPM (121.9 MPM)
HEAD SHAFT RPM	124	109	94	83
HOUSING GAUGE, GALVANIZED	12 Ga. (2.7 mm)	12 Ga. (2.7 mm)	12 Ga. (2.7 mm)	10 Ga. (3.4 mm)
PADDLE THICKNESS (UHMW)	3/8" (9.5 mm)	3/8" (9.5 mm)	1/2" (12.7 mm)	1/2" (12.7 mm)
CORNER SHAFT DIAMETER	1-1/2" (38.1 mm)	2" (50.8 mm)	3" (76.2 mm)	3-7/16" (87.3 mm)
CONVEYOR CHAIN	81 X	81 XHH	81 XHH	81 XHH
CONVEYOR SPROCKET	12 Tooth	14 Tooth	16 Tooth	22 Tooth
CONVEYOR HP (kW) REQUIRED* - PER FOOT (METER) VERTICAL - PER FOOT (METER) HORIZONTAL	.20 HP (.48 kW) .05 HP (.12 kW)	.35 HP (.85 kW) .08 HP (.19 kW)	.50 HP (1.20 kW) .11 HP (.27 kW)	.75 HP (1.80 kW) .18 HP (.44 kW)
WEIGHT PER FOOT OF TUBULAR CONVEYOR - EMPTY - FULL OF 56 LB. PER BU MATERIAL	10.5 lbs/ft 19.5 lbs/ft	18.0 lbs/ft 34.0 lbs/ft	20.0 lbs/ft 45.0 lbs/ft	26.5 lbs/ft 63.0 lbs/ft
WEIGHT PER METER OF TUBULAR CONVEYOR - EMPTY - FULL OF 56 LB. PER BU MATERIAL	14.9 kg/m 28.3 kg/m	17.9 kg/m 41.7 kg/m	22.0 kg/m 59.5 kg/m	35.7 kg/m 89.3 kg/m

\* Clean, dry, and non abrasive grain

# Commercial Grain Pump



Installation of Commercial Grain Pump loop system into flat storage structure.

The Hutchinson Grain Pump™ is designed for new or existing storage installations.

## COMMERCIAL GRAIN PUMP

	10" LOOP	12" LOOP	16" LOOP
DIMENSIONS OF CONVEYING CHAMBER	10" (25.4 cm)	12" (30.5 cm)	16" (40.6 cm)
MAXIMUM CAPACITY*	6,000 BPH (162 TPH)	10,000 BPH (270 TPH)	18,000 BPH (486 TPH)
CHAIN TRAVEL	325 FPM (99.1 MPM)	400 FPM (121.9 MPM)	400 FPM (121.9 MPM)
HEAD SHAFT RPM	67	83	63
HOUSING GAUGE, GALVANIZED	10 Ga. (3.4 mm)	10 Ga. (3.4 mm)	7 Ga. (4.5 mm)
PADDLE THICKNESS (UHMW)	1/2" (12.7 mm)	1/2" (12.7 mm)	5/8" (15.9 mm)
CORNER SHAFT DIAMETER	3-7/16" (87.3 mm)	3-7/16" (87.3 mm) - thru 60 HP 3-15/16" (100.0 mm) - 75 & 100 HP	Variable
CONVEYOR CHAIN	81 XHH	81 XHH - thru 60 HP Double 81 XHH 75 & 100 HP	WH 124
CONVEYOR SPROCKET	16 Tooth (Non-Drive Corners) 22 Tooth (Drive Corners)	22 Tooth	19 Tooth
CONVEYOR HP (kW) REQUIRED* -PER FOOT (METER) VERTICAL -PER FOOT (METER) HORIZONTAL	.50 HP (1.20 kW) .11 HP (.27 kW)	.75 HP (1.80 kW) .18 HP (.44 kW)	1.35 HP (3.30 kW) .30 HP (.73 kW)
WEIGHT PER FOOT OF TUBULAR CONVEYOR - EMPTY - FULL OF 56 LB. PER BU MATERIAL	23.0 lbs./ft. 48.0 lbs./ft	26.5 lbs./ft. - Single Chain 31.0 lbs./ft. - Double Chain 63.0 lbs./ft. - Single Chain 67.5 lbs./ft. - Double Chain	46.0 lbs./ft 133.0 lbs./ft
WEIGHT PER METER OF TUBULAR CONVEYOR - EMPTY - FULL OF 56 LB. PER BU MATERIAL	34.2 kg/m 71.4 kg/m	39.4 kg/m - Single Chain 46.1 kg/m - Double Chain 93.7 kg/m - Single Chain 100.4 kg/m - Double Chain	68.4 kg/m 198.0 kg/m

\* Clean, dry, and non abrasive grain

# Stationary Double Run



Stationary grain pumps can be used in various applications at angles from horizontal to 60°. Lengths available in 5' increments. A flow through inlet is convenient for overhead applications.

Cross section of housing

## STATIONARY GRAIN PUMP | DOUBLE RUN SYSTEM SPECIFICATIONS

	6" DOUBLE RUN	8" DOUBLE RUN	10" DOUBLE RUN	12" DOUBLE RUN
DIMENSIONS OF CONVEYING CHAMBER	6" (15.2 cm)	8" (20.3 cm)	10" (25.4 cm)	12" (30.5 cm)
MAXIMUM CAPACITY*	1,500 BPH (41 TPH)	4,000 BPH (108 TPH)	16,000 BPH (162 TPH)	10,000 BPH (270 TPH)
CHAIN TRAVEL	338 FPM (103.0 MPM)	329 FPM (11.3 MPM)	348 FPM (106.1 MPM)	400 FPM (121.9 MPM)
HEAD SHAFT RPM	126	126	114	102
GALVANIZED HOUSING	12 Ga. (2.7 mm)	12 Ga. (2.7 mm)	12 Ga. (2.7 mm)	10 Ga. (3.4 mm)
PADDLE THICKNESS (UHMW)	3/8" (9.5 mm)	3/8" (9.5 mm)	1/2" (12.7 mm)	1/2" (12.7 mm)
HEAD SHAFT DIAMETER	1-1/2" (38.1 mm)	2" (50.8 mm)	2" (50.8 mm)	3-7/16" (87.3 mm)
BOOT SHAFT DIAMETER	1-1/2" (38.1 mm)	2" (50.8 mm)	2" (50.8 mm)	3-7/16" (87.3 mm)
CONVEYOR CHAIN	81 X	81 X	81 XHH	81 XHH
CONVEYOR SPROCKET	12 Tooth	12 Tooth	14 Tooth	18 Tooth



Stationary Double Run filling a dryer and unloading dryer to multiple bins.

#### DOUBLE RUN SYSTEM | HORSEPOWER TABLE

	ANGLE OF OPERATION	HORIZONTAL	15	30	45	60	90
6" DOUBLE RUN	HP per Foot (kW per Meter)	0.042 0.102	0.062 0.151	0.085 0.207	0.120 0.292	0.140 0.341	N/A
8" DOUBLE RUN	HP per Foot (kW per Meter)	0.076 0.185	0.113 0.275	0.167 0.407	0.222 0.541	0.270 .658	N/A
10" DOUBLE RUN	HP per Foot (kW per Meter)	0.114 0.278	0.170 0.414	0.250 0.610	0.333 0.812	0.405 0.988	0.5 1.2
12" DOUBLE RUN	HP per Foot (kW per Meter)	0.180 0.439	0.268 0.654	0.397 0.968	0.524 1.278	0.629 1.534	N/A

# 10" Vertical Double Run Grain Pump



## Features

- Up to 6,000 BPH capacity
- 10' minimum amount of required horizontal space
- Maximum discharge height of 68' with total equipment height of 72'
- Drives 15-40 HP (Dodge Reducer)
- Chain Speed 348 FPM

## Applications

- Wet fill systems to dryers
- Dry grain transfer from dryers
- Receiving grain



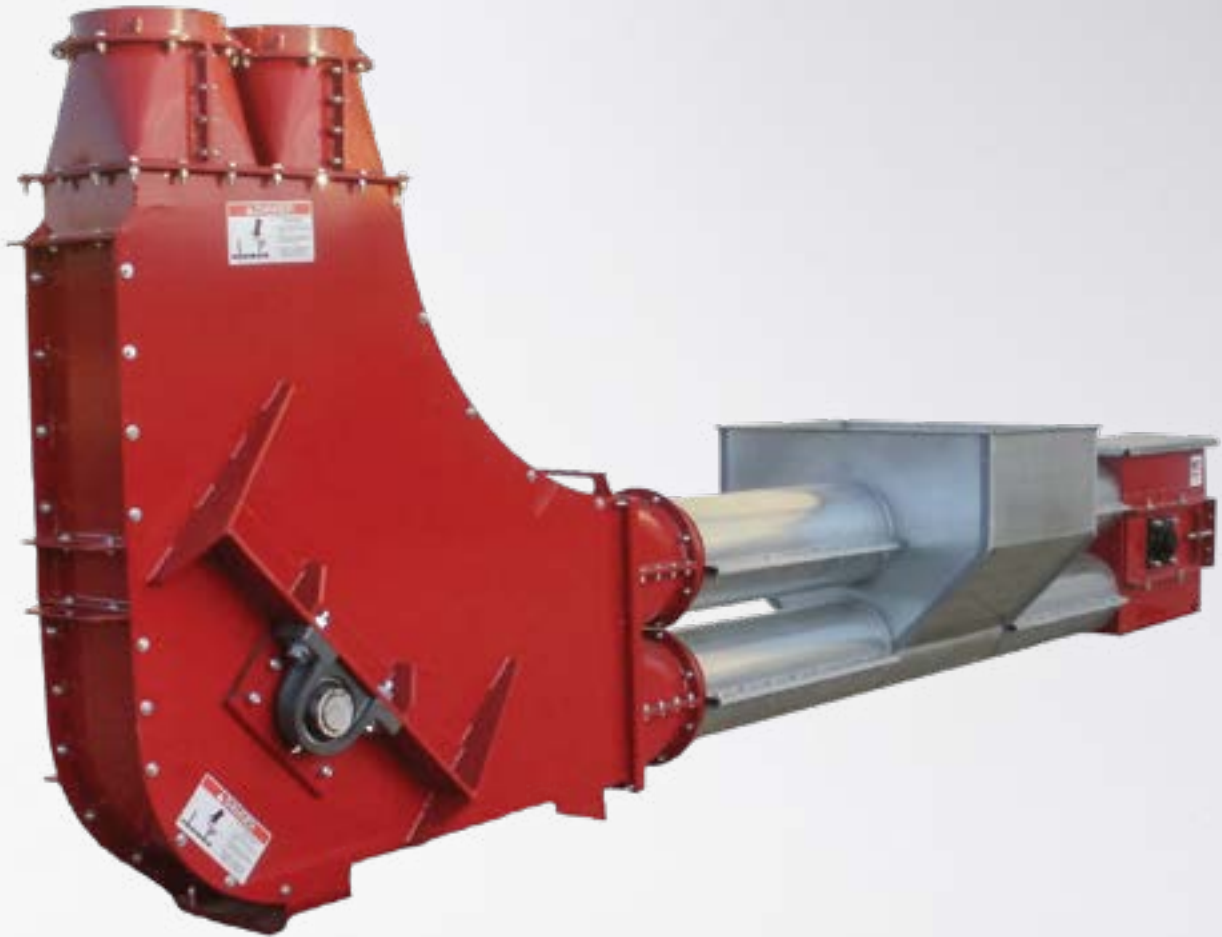

## 10" VERTICAL DOUBLE RUN GRAIN PUMP SPECIFICATIONS

MODEL	MAX DISCHARGE HEIGHT	DRIVES	CHAIN SPEED
10" DOUBLE RUN	68' (20.73 m)	15 - 40 HP	348 FPM

### Equipment Highlights

- 81 XHH Chain
- 1/2 UHMW Paddles
- Bypass Inlet
- Corner and head manufactured with 7 ga. material
- Bolt-In AR Liner on the bottom of the corner
- Removable access doors provided with handles
- Chain tension on the boot assembly for easy chain adjustment
- 5' and 10' Dump Hoppers

# Mass-Ter Mover & Mass-Ter Flow

## **Mass-Ter Mover® features a unique chain and paddle design.**

The heart of the Hutchinson Mass-ter Mover® is a continuous chain and paddle combination that utilizes the “en masse” concept. The unique shape of tough Ultra High Molecular Weight (UHMW) paddles maintains full chamber movement of grain - without fall-back. The open centers of the paddles provide relief when starting under a full load. The square paddle propulsion system requires less horsepower than a screw conveyor (up to 30% energy savings can be gained)! Whether you’re starting from the ground up, or updating your present facilities, you’ll find the Hutchinson Mass-ter Mover ready to meet your demands.

## **Mass-Ter Flow® Drag Conveyor - economy and quality in a horizontal conveyor.**

The Mass-ter Flow® Drag Conveyor is designed with the same quality features as the Mass-ter Mover®. The Mass-ter Flow® is economical in higher capacities, where design allows a strictly horizontal conveyor. High working strength roller chain is combined with tough Ultra High Molecular Weight (UHMW) polyethylene paddles for long life and smooth operation. Optional bottom AR plate liner is available for extra life, particularly in very dirty grain conditions.

1. Drive-over Mass-ter Mover® pit hopper
2. Bin sweep
3. Return Mass-ter Mover® or Mass-ter Flow (Mass-ter Mover illustrated)
4. Bin unloading Mass-ter Mover® with incline drive
5. Overhead Mass-Ter Flow (Mass-ter Mover illustrated)



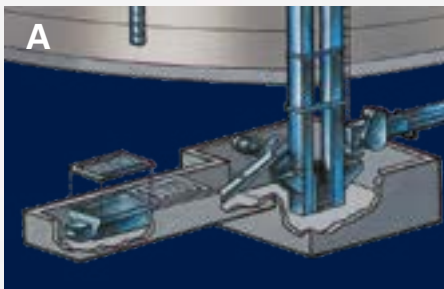

**Accessories that make Hutchinson the MASS-TER of material moving systems.**

Mass-ter Mover® and Mass-ter Flow® accessories provide a complete loading and unloading system for storage structures. Bin unloading units normally incorporate multiple inlets with slide gates and sweep pivots where needed. The usual choices of drives and elbow combinations are available on the Mass-ter Mover® (Mass-ter Flow is horizontal only). Drive-over pit hopper (photo A) with 30°, 45° or 90° incline sections for a dump-and-go operation without a costly holding pit. Swing-away hopper (photo B) and portable hopper (photo C) allow you to custom design your handling system.

# Mass-Ter Mover Features

- Mass-ter Mover® powerheads may be used horizontally or in conjunction with the newly designed elbows for inclined or vertical discharge. (15°, 30°, 45° and 90° elbows available in select models)
- Hutchinson's "square paddle" propulsion system requires less horsepower than a screw conveyor. (Up to 30% energy savings)
- Capacities from 2,500 (68 TPH) to 15,000 BPH (473 TPH).  
Single horizontal lengths to 200'
- Grain slides through a full lower chamber with no pinch points to damage material
- The unique paddle design allows the Mass-ter Mover® to operate at various inclines
- Component system adapts to a variety of uses: drive-over pit; horizontal or inclined storage loading; bottom unloading; filling or unloading from dryer

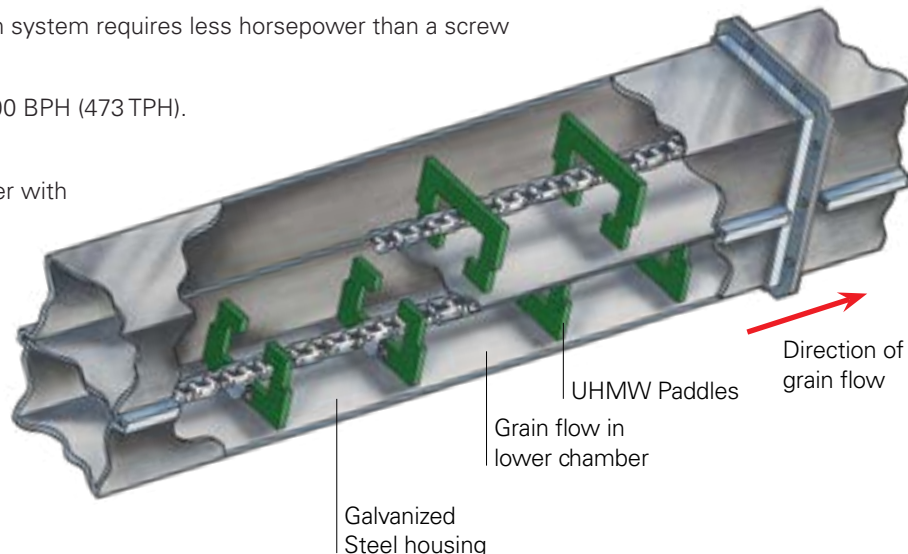

## MASS-TER MOVER® SPECIFICATIONS

	MODEL 50	MODEL 85	MODEL 150
DIMENSIONS OF CONVEYING CHAMBER	6" x 9" (15.2 cm x 22.9 cm)	7" x 13" (17.8 cm x 33.0 cm)	10" x 17" (25.4 cm x 43.2 cm)
CAPACITY IN BPH*	2,500 - 5,000 BPH (68 - 135 TPH)	4,100 - 10,000 BPH (111 - 270 TPH)	7,500 - 15,000 BPH (203 - 405 TPH)
CHAIN TRAVEL	150 - 325 FPM (45.7 - 99.1 MPM)	150 - 400 FPM (45.7 - 122.0 MPM)	150 - 350 FPM (45.7 - 106.9 MPM)
HEAD SHAFT RPM	58 - 125	43 - 114	28 - 114
HOUSING GAUGE, GALVANIZED			
- GAUGE OF BOTTOM	10 Ga. (3.4 mm)	10 Ga. (3.4 mm)	10 Ga. (3.4 mm)
- GAUGE OR PARTITION	12 Ga. (2.7 mm)	12 Ga. (2.7 mm)	12 Ga. (2.7 mm)
- GAUGE OF TOP	14 Ga. (1.9 mm)	14 Ga. (1.9 mm)	14 Ga. (1.9 mm)
PADDLE THICKNESS (UHMW)	3/8" (9.5 mm)	1/2" (12.7 mm)	5/8" (15.9 mm)
TAKE-UP LOCATION	Head	Head	Head
DISCHARGE	12" (30.48 cm) Round	14" (35.6 cm) Round	16" (40.6 cm) Square
CONVEYOR CHAIN	81 X	81 XHH	Double 81 XHH
CONVEYOR SPROCKET	12 Tooth	16 Tooth	25 Tooth
APPROX. CONVEYOR WEIGHT (LBS/FT)			
- EMPTY	38.0 lbs./ft.	57.0 lbs./ft.	135.0 lbs./ft.
- LOADED	55.0 lbs./ft.	85.0 lbs./ft.	185.0 lbs./ft.
APPROX. CONVEYOR WEIGHT (KG/M)			
- EMPTY	(57.0 kg/m)	(84.0 kg/m)	(201.0kg/m)
- LOADED	(82.0 kg/m)	(126.0 kg/m)	(275.0 kg/m)

\* Horizontal @ 15% Moisture

# Mass-Ter Flow Features

- Shallow paddles running in this single chamber conveyor provide deep layer, high volume grain movement
- The conveyor covers are easily removed for clean out
- Optional AR plate liner is available for extra life in very dirty grain conditions
- Capacity is from 2,500 BPH (68 TPH) to 15,000 BPH (405 TPH). Single runs to 240'
- Mass-ter Flow units are available as stationary overhead or return conveyors and bottom unloading systems
- Optional reversible drive available for two-way operation
- Electrically controlled intermediate rack and pinion gates available

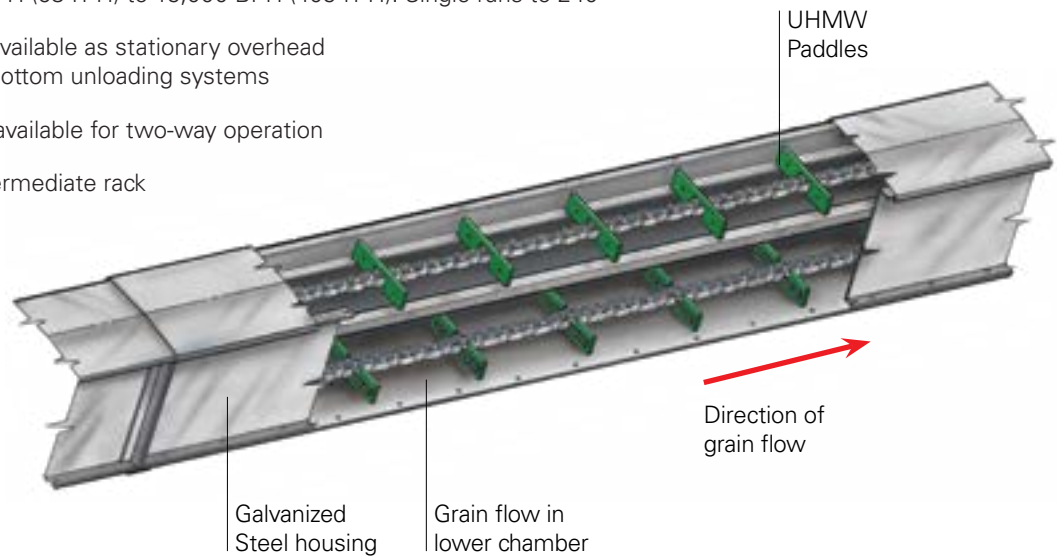

## MASS-TER FLOW® SPECIFICATIONS

	9" MASS-TER FLOW	13" MASS-TER FLOW
DIMENSIONS OF CONVEYING CHAMBER	9" x 14-3/4" (22.9 cm x 37.5 cm)	13" x 16-7/8" (33.0 cm x 42.9 cm)
CAPACITY IN BPH*	2,500 - 7,000 BPH (68 - 189 TPH)	2,500 - 15,000 BPH (68 - 405 TPH)
CHAIN TRAVEL	80 - 320 FPM (24.4 - 97.5 MPM)	130 - 260 FPM (39.6 - 79.3 MPM)
HEAD SHAFT RPM	30 - 120	37 - 75
HOUSING GAUGE, GALVANIZED		
- GAUGE OF BOTTOM	10 Ga. (3.4mm)	10 Ga. (3.4mm)
- GAUGE OF SIDES	12 Ga. (2.7 mm)	12 Ga. (2.7 mm)
- GAUGE OF TOP	16 Ga. (1.5 mm)	16 Ga. (1.5 mm)
- GAUGE OF HEAD	12 Ga. (2.7 mm)	12 Ga. (2.7 mm)
- GAUGE OF BOOT	10 Ga. (3.4 mm)	10 Ga. (3.4 mm)
PADDLE THICKNESS (UHMW)	3/8" (9.5 mm)	3/8" (9.5 mm)
TAKE-UP LOCATION	Head	Head
CONVEYOR CHAIN	81 X	81 XHH
CONVEYOR SPROCKET	12 Tooth	16 Tooth

\*Approximately 1/3 capacity loss on highly abrasive grains (soybeans, popcorn, rice, feed stuffs, etc.). Moisture from dryer vent and humidity can affect capacity.

# Dual Hopper Chain Conveyor



## Dual Hopper Chain Conveyor

- Impressive 10,000, 15,000 and 20,000 BPH capacities available
- Unload both trailer hoppers at the same time
- Matches the capacity of 12" Double Run Grain Pump, Low Profile Chain Conveyor, Mass-ter Mover® Chain Conveyor, 16" Loop and Model 150 Mass-ter Mover



### **Features**

- Direct drive to prevent slipping, adjustment and breaking
- Heavy duty construction
- 44" width grates
- Spring take-up for constant tension and less maintenance
- Trunk extensions are available
- Uses 15:1 main gearbox connected to 1:1 right angle gearboxes to drive two separate conveyors
- Use a variable frequency drive controller to adjust speed and flow

### **Heavy Duty Construction**

- 7 ga. laser cut sheet steel
- 3/8" Laser cut flange connections
- AR wear plate for divider panel

### **Grates**

- 44" width opening
- Drive-over grating meets OSHA Standards 1910.272



STORAGE

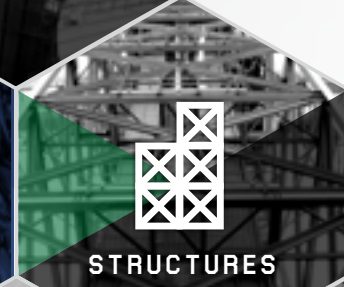

STRUCTURES



HANDLING



PROCESS



CONTROLS

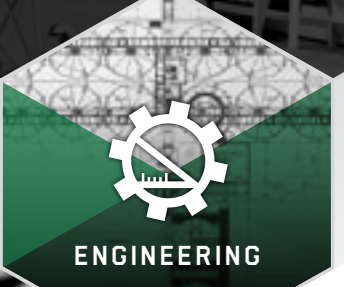

ENGINEERING



PROJECT  
MANAGEMENT

**Hutchinson is an AGI brand.**

AGI is a leading manufacturer of grain, seed, feed, food and fertilizer handling, blending, storage and conditioning equipment. Our brands are amongst the most recognized in the industry. The AGI product catalog includes portable handling equipment (augers, belt conveyors, grain vacs), permanent handling systems (bucket elevators, enclosed belt conveyors, chain conveyors, structural) and storage systems (aeration, drying, bins/silos, monitoring) that service various sectors for on-farm and commercial operations.

# **AGI HUTCHINSON**

P.O. Box 629, 74, Clay Center, Kansas, USA 67432

P 785.632.2161 | [hutchinson-mayrath.com](http://hutchinson-mayrath.com)

[AGGROWTH.COM](http://AGGROWTH.COM)

 @aggrowthintl

0818